

# QUICK INSTALATION GUIDE

## AQUASCENIC

sugar.valley

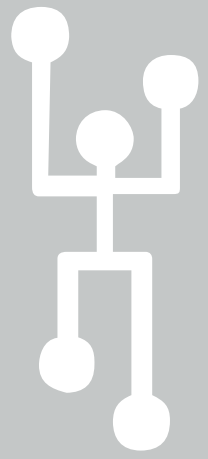

### 1 DESCRIPTION

With the Hydrolysis system we produce active agents like Oxygen, Hydrogen peroxide, OH, Ozone ... on the bases of Water (H<sub>2</sub>O - with a minimum conductivity of 1000mS). While the Water passes through the hydrolysis cell these oxidative agents are produced by braking up the H<sub>2</sub>O molecule in its components. Organic mater present in the water is oxidized and eliminated – the water is purified. While the water returns to the swimming pool the produced active agents reconvert into Water. This process is combined with a Copper Silver ionisation which provides us with a constant flocculation and an additional disinfectant, eliminating bacteria and algae. The result is exceptional clear and transparent Water.

#### Electronic unit

- 1 Ioniser Cu/Ag
- 2 Hydrolysis
- 3 RCA flow detector
- 4 pH probe
- 5 Redox probe
- 6 Mains connection 220v.
- 7 3.15A fuse
- 8 250 mA fuse
- 9 On-off switch
- 10 Air vent
- 11 Acid pump connection



#### Cell

- 1 Hydrolysis cell
- 2 RCA flow detector
- 3 Cell connection
- 4 Flow/gas detector
- 5 Cell housing



#### Electrode housing

- 1 Electrode housing (2/4/6 e)
- 2 Copper/silver electrodes
- 3 Electrode bolt
- 4 Electrode cable
- 5 Concentric seal
- 6 Gasket



#### Optional extras

##### pH probe

- 1 Probe
- 2 Probe casing
- 3 Connection housing



##### Redox probe

- 1 Probe
- 2 Probe casing
- 3 Connection housing



##### Conductivity probe

- 1 Probe
- 2 Probe casing
- 3 Connection housing



## 2 INSTALLATION

### Electrical consumption

	Maximum consumption	Recommended protection
HD 1	180W	10A
HD 2	228W	10A
HD 3	600W	16A
HD 4	1020W	16A
HD 5	1440W	25A
HD 6	1620W	25A

### TITANIUM CELL connection overheating



Ensure all electrical connections are firmly fixed to avoid false contacts and subsequent overheating of system components (Especially concerning the Hydrolysis cell with usage above 33A).

### AQUASCENIC Synchronized with Filtration



Ensure the hydrolysis unit is synchronized with the pool filtration and stops functioning when water circulation has stopped.

### System installation diagram

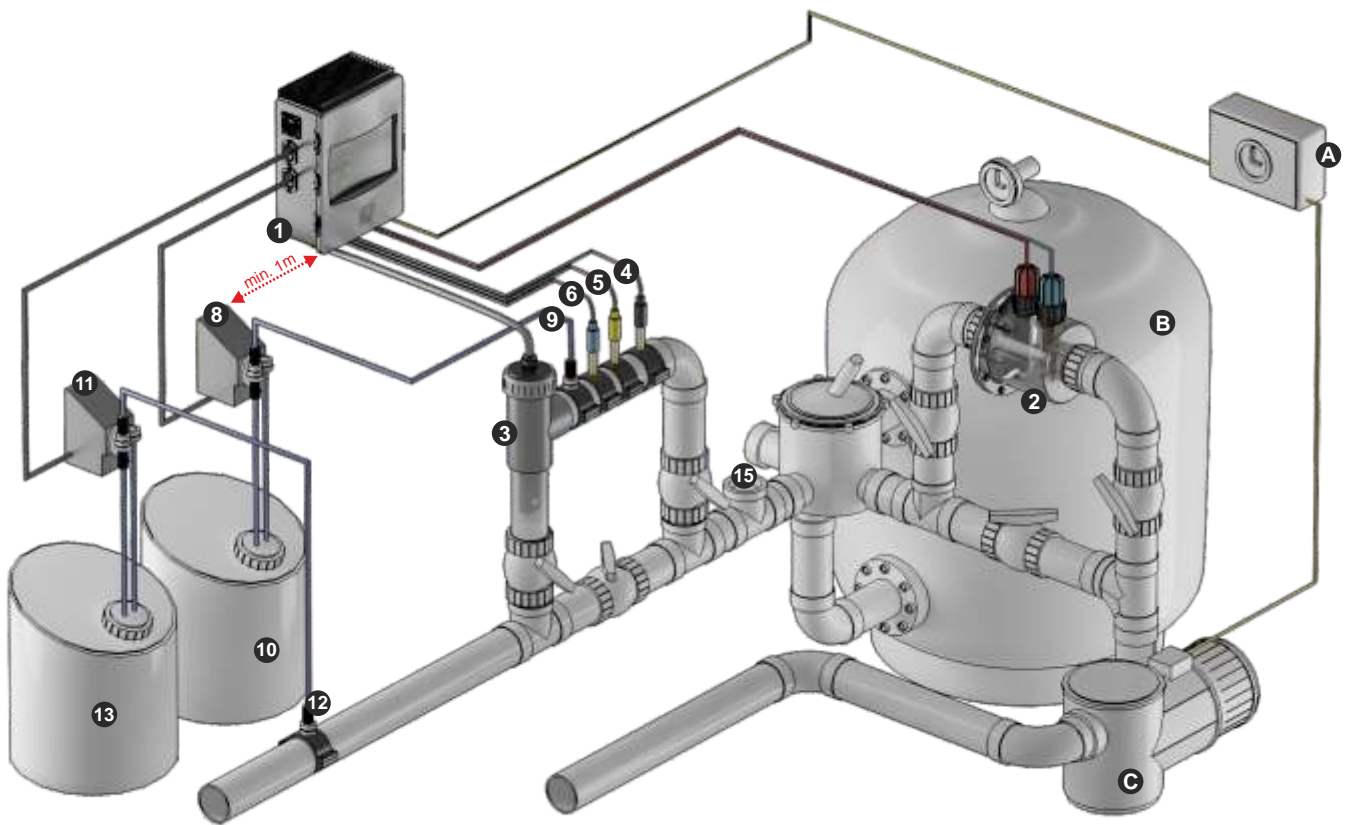

- A Filtration pump timer
- B Sand filter
- C Recirculation pump
- 1 Electrical housing
- 2 Cu/Ag electrodes casing
- 3 Hydrolysis cell (always in vertical position)
- 4 pH probe (Optional, for models with PH control)
- 5 Redox probe (Optional, for models with redox control)
- 6 Conductivity probe (Optional, for models with conductivity control)
- 8 Acid pump (Optional, for models with PH control)
- 9 Acid injector (Optional, for models with PH control)
- 10 Hydrochloric acid container (optional, for models with PH control, not supplied with unit)
- 11 Chlorine pump (Optional, for models with redox or free chlorine control + auxiliary chlorine dosage)
- 12 Chlorine injector (Optional, for models with redox or free chlorine control)
- 13 Chlorine container (Optional, for models with redox or free chlorine control, not supplied with unit)
- 15 1. Other pool equipment (pool heating, heat exchanger, etc.)

### 3 AJINITIAL ADJUSTMENTS

#### Initial adjustments

1. Adjust the alkalinity between 90 and 110 ppm.
2. Adjust the PH between 7,2 and 7,4
3. Adjust the chlorine between 1 and 1,5 ppm.

SHOULD the water be supplied from a well: shock chlorinate with Tricloroisocyanuric acid (2Kg./50m3 of water)

#### Conductivity adjustments

In poorly conductive waters add 1Kg. of sodium chloride (NaCl) for every m3 of pool water.

IN POOLS WHICH RECEIVE LARGE AMOUNTS OF STRONG SUNLIGHT 30gr/m3 OF STABILYSER (Isocyanuric acid) MUST BE ADDED

This will not be necessary for covered pools.

### 4 START UP

#### Electronic housing display



#### Start up

**LO** : **Conductivity/Cell life**  
 Low conductivity (See section 3)  
**19** : Titanium cell incrustated (See cleaning process in section 5)  
 Cell surface corroded (See section 7)

**FL1** : **Insufficient FLOW or cell disconnected**  
 Production halted due to lack of flow, or gas in the titanium cell detector.

**OFF** : **ONLY SYSTEMS WITH REDOX OR FREE CHLORINE**  
 The system has automatically stopped as Redox levels are above the chosen values (See section 5)

**FL2** : **ONLY SYSTEMS WITH FREE CHLORINE CONTROL (ppm's)**  
**INSUFFICIENT FLOW in the CHLORINE detector.**  
 The rotary sensor detects insufficient flow. CHECK the rotameter pendel – and solve the system's hydraulic problem (If there is a preceding filter this must be cleaned).

**0** : **Time delay**  
 Period of non-production while system changes polarity (0-120 sec.)

**Pr--** : **IONIZATION INTERVAL PROGRAMMER**  
 The system is programmed to ionize for a predetermined period each time it is started up:  
**Pr--** : Will run continually.  
**Pr30** : Will run for 30 min. following start up.  
**Pr60** : Will run for 60min. following start up.  
**Pr90** : Will run for 90min. following start up.

**100** : **WORN ELECTRODES or low conductivity**  
 The production level shown presently on screen corresponds to less than 50% of the preselected level. Electrodes may be worn or water conductivity low.

**AL** : **ALARM**  
 Excessive increase or decrease in parameters (+/- 15% from the selected parameters).  
 CHECK LEVELS IN ACID/BASE CONTAINERS  
 CHECK PROBE CALIBRATION

## 5 SYSTEMS WITH REDOX CONTROL

The Redox level advises us of the potential oxidization or reduction level and is used to determine the level of water sterilization. The parameters or Set Points are the minimum/maximum accepted REDOX levels before the titanium cell is connected/disconnected.

Adjusting the ideal REDOX level (set point) is the last step in the AQUASCENIC start up sequence. To find the optimum REDOX level for your pool follow these steps:

1. Connect the pool filtration system (The salt in the pool must be adequately dissolved).
2. Add chlorine to the pool till a level of 1-1,5ppm. Is achieved (Approx. 1-1,5gr/m<sup>3</sup> of water). PH levels should be between 7,2 and 7,5.
3. After 30 min. test the free chlorine levels in the pool (DPD1 manual test kit) If the free chlorine level is between 0,8-1,0ppm. Look at the REDOX screen and memorize this level as the set point to CONNECT/DISCONNECT the hydrolysis cell (To memorize the set point see section 8)
4. The next day check free chlorine levels (manual DPD1 test kit)and REDOX, Raise/lower set point if necessary

## 6 MAINTENANCE

### Initial maintenance

During the first 10-15 days your pool system will require more attention and the following care:

During the Use of the Ionizer it is important not to exceed copper concentrations of more than 0,5 PPM in the water. For this reason it is mandatory to measure copper levels during the initial phase (first weeks) and to readjust copper production between 20 to 50 after establishing 0,5 ppm copper in the water. Furthermore the time limitation Pr30 (see chapter 7 menu) has to be initiated.

**2 CHECK THE PH REMAINS BETWEEN THE IDEAL LEVELS (7,2-7,4).** If the PH is unusually unstable AND USES A LOT OF ACID check the alkalinity (Recommended levels between 80 and 125ppm.).

**3 The pool must be vacuumed and the skimmers cleaned whenever necessary to ensure perfect water conditions.**

**REMEMBER** that the Sugar Valley system requires a certain amount of time to adapt to your swimming pool and will require additional chemicals during the first 3-5 days.

### Titanium cell maintenance

Cleaning the Titanium cell: Maintenance of the disinfection system (hydrolysis) consists of cleaning the cell or electrode every 2-3 months should it appear necessary (carry out a visual inspection) To clean the electrode:

- Remove the cell from its support (after turning off the filtration system and closing off the necessary valves).
- Place the electrode for no more than 10 min. in 15% HYDROCHLORIC ACID (sulfumant).
- Once the incrustations have softened remove with a hose to complete cleaning the cell.

USE NO METALIC OR SHARP OBJECTS TO REMOVE INCRUSTATIONS. Scratching the edges or surface of the cell will make it vulnerable to chemicals, deteriorate the cell and annul the guarantee.

### Fortnightly checks

<b>FREE chlorine</b>	: 1.0 – 2.0 PPM
<b>pH</b>	: 7,1 – 7,5
<b>Copper concentration</b>	: 0,3 – 0,5 PPM

### Monthly checks

<b>TOTAL (TAC) alkalinity</b>	: 80-120 ppm
<b>Salt concentration</b>	: 800 – 1500 ppm
<b>Cyanuric acid</b>	: 30-50 ppm
<b>Titanium cell</b>	: Inspección visual para determinar incrustaciones.

### General maintenance

1-The pool must be vacuumed as usual and the skimmers emptied whenever necessary.

2-Filter backwashing: with Sugar Valley systems the filter requires only occasional backwashing; once every 20 days should be sufficient (providing the filter pressure does not exceed 1 bar, in which case a backwash may be necessary).

**VERY IMPORTANT;** Ensure that the Sugar Valley system is turned off during filter backwashing.

3-ADDING NEW WATER: Always through the skimmers so that the new water passes through the Aquascenic before entering the pool. Remember to add the necessary salt: 1gr. per added litre of water.

4-In winter CHANGING THE POOL WATER IS NOT RECOMMENDABLE. We recommend that the system runs 2-3 times per week (2-3hrs. per day).

DOSAGE PUMPS: Check regularly to ensure that the container contains liquid to prevent the dosage pump running dry. The dosage pump requires maintenance (INSTRUCTIONS ON BOX).

PH PROBES/REDOX/CONDUCTIVITY: Probes must be cleaned whenever necessary (check every 5-6 months). To clean the probe insert in distilled water (Clear liquid). After each cleaning the probes must be calibrated.

# 7 MENU ACCESS

## Accessing user menu



HOLD FOR 3 SECONDS TO ACCESS  
EXIT USER MENU



## Displays

- 1 Ionization level
- 2 Hydrolysis level
- 3 pH Control
- 4 Redox / Free chlorine control
- 5 Conductivity control



## User menu



### LEVEL OF Cu/Ag ION PRODUCTION **DISPLAY 1**



To modify level RECOMMENDED VALUE BETWEEN 20-50



To confirm and change menu screen



RECOMMENDED CONFIGURATION Pr30

### OXIDISATION LEVEL **DISPLAY 2**



To modify level RECOMMENDED LEVEL: MAXIMUM POWER 100%



To confirm and change menu



### pH SET POINTS **DISPLAY 3**

To LOWER pH - maximum water pH - CONTROLS THE ACID PUMP (optional equipment)



To modify parameters/maximum pH set point RECOMMENDED LEVEL: 7,2 - 7,5



To increase pH - minimum water pH - CONTROLS THE base PUMP (optional equipment)



To modify parameters/minimum pH set point RECOMMENDED LEVEL: 6,8



Insert probe in pH 7 sample, wait till reading has stabilized



Clean probe in NEUTRAL. Insert probe in pH 10 sample and wait till reading is stable.



Calibration correct  
Repeat calibration or change probe

### Redox SET POINT **DISPLAY 4**



To modify parameters / Redox set point



To confirm and change menu



Insert probe into 465mv sample, wait till reading is stable.



Calibration correct

Repeat calibration or change probe.

### CONDUCTIVITY SET POINT **DISPLAY 5**



To modify parameters / conductivity setpoint



To confirm and change menu



Insert the probe in sample, wait until reading is stable.



Change conductivity reading to match sample.



Calibration correct  
Repeat calibration or change probe.



To change menu and return to Ion menu.



## 8 TROUBLESHOOTING

### Display blank

- \*Check On/Off switch is illuminated.
- \*Check external 250mA fuse has not fused.
- \*Check electric supply: 210-230V 50Hz
- \*If problem persists contact TECHNICAL SERVICE.

### Hydrolysis does not reach maximum intensity

- \*Check sodium bromide or common salt concentration in water.
- \*Check cell status (may be incrustated or calcified).
- \*Clean electrode following instructions in section 6.
- \*Clean flow detector situated in the cell casing.
- \*Check titanium cell is not worn (remember that the cell is guaranteed for 5000-6000 hours (approx. 2-3 years of Summer usage)- see troubleshooting for more information).

### Free chlorine levels don't reach 0,2ppm. First thing in the morning

- \*INCREASE FILTRATION INTERVAL.
- \*INCREASE hydrolysis level.
- \*Check levels of sodium bromide or common salt in the pool (1gr.NaCl/L).
- \*Check level of isocyanuric acid in pool (30-50ppm.) ONLY if using COMMON SALT.
- \*Check reactive agents in test kit are not TOO OLD.
- \*Has the temperature or amount of users risen (see 3.1/3.2 see chapter "Water maintenance").
- \*pH is above 7,8 and must be adjusted.

### Hydrolysis display shows LO

- \*Water lacks conductivity (see section 3 "water preparation").
- \*Check for incrustations on cell.
- \*See troubleshooting "Hydrolysis does not reach maximum intensity".

### Hydrolysis display shows FL

- \*Check flow detector cable.
- \*Clean incrustations of flow detector at top of cell casing.
- \*Check system is free of air (Probe must be always submerged).

### Polarity 1 reaches max. intensity but polarity 2 (Auto clean) does not

- \*When polarity 2 does not reach 50% we recommend substituting cell for a new one if during the summer or maximum usage period. If this should happen in winter change before the next season (summer).

### EXCESS OXIDATION in water

- \*Lower Hydrolysis cell level.
- \*If your system includes AUTOMATIC REDOX CONTROL check REDOX SETPOINT.
- \*Check REDOX probe and calibrate if necessary.

### Titanium cell incrustated in less than 1 month

- \*Very hard waters with a high pH and total alkalinity (Balance water adjusting pH and total alkalinity).
- \*Check to ensure the system automatically changes polarity (LED's alternate every 300min. approx.).
- \*CONSULT with our technical service to consider ACCELERATING THE polarity change (Auto-cleaning) WARNING: accelerating the polarity change decreases the cell life proportionally.

### White flakes in pool

- \*This happens in excessively hard unbalanced waters.
- \*Balance the water and check the cell, proceeding to clean it if necessary.

### RUST on metallic components in pool

- \*Metallic elements lack standardized earth connection. Contact an electrician to solve.
- \*Rusted components are not stainless steel: minimum 304- recommended 316.

### WARNING

Keep chemical levels in pool as instructed in this manual

### CLEANING FILTER

Ensure AQUASCENIC is NOT RUNNING during backwash.

### VERY IMPORTANT

REMEMBER that the system needs some time to adapt to your pool and you will have to increase chemical levels for the first 5 days.

### EARTHING

All metallic components in the pool, such as lamps, ladders, heat exchangers, drains or similar elements within 3.00m. from pool (10feet) must be connected to an earth below 37Ohms.

WE RECOMMEND HEAT EXCHANGERS BE MADE OF TITANIUM.

### SECURITY

To avoid accidents this product should not be handled by children unless supervised by an adult. Children should be supervised at all times when in or near a spa, pool or Jacuzzi.

### HANDLING AND DOSING DANGEROUS CHEMICALS

Chemicals should be handled with extreme precaution. When preparing ACID, ALWAYS ADD THE ACID TO WATER, never add water to acid!!! VERY dangerous gasses may be produced.

